

TECHNICAL INFORMATION  
AND  
SERVICE DATA

**RADIOLA**

Models 609-T, 707-C & 803-G

SIX VALVE, SEVEN BAND,  
A.C. OPERATED SUPERHETERODYNES

ISSUED BY  
AMALGAMATED WIRELESS (A/SIA.) LTD.

609-T, 707-C & 803-G

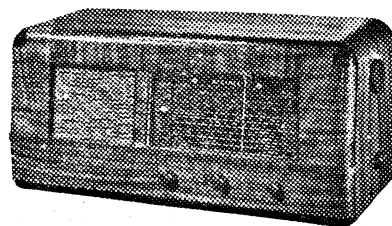

609-T

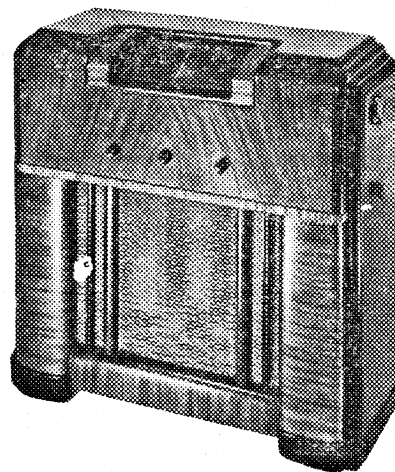

707-C

NOTE: Model 803-G is not illustrated.

**ELECTRICAL SPECIFICATIONS.**

FREQUENCY RANGES:

- (1) 1500-550 kc. .... (200-545 M.)
- (2) 4.0-1.5 Mc. .... (75-200 M.)
- (3) 9.7-3.6 Mc. .... (31.0-83.4 M.)
- (4) 12.0-9.4 Mc. .... (25.0-31.9 M.)
- (5) 15.0-11.7 Mc. .... (20.0-25.7 M.)
- (6) 19.0-15.0 Mc. .... (15.8-20.0 M.)
- (7) 22.3-17.7 Mc. .... (13.5-16.9 M.)

INTERMEDIATE FREQUENCY 455kc.

POWER SUPPLY RATING ....200-260 V. A.C., 50-60 C.P.S.  
(Models are produced with other voltage and frequency ratings.)

POWER CONSUMPTION .... 80 watts

VALVE COMPLEMENT:

- (1) 6U7G R.F. Amplifier.
- (2) 6J8G Converter.
- (3) 6U7G I.F. Amplifier.
- (4) 6G8G/6B8G Det., A.V.C. and A.F. Amplifier.
- (5) 6V6GT/G Output
- (6) 5Y3GT/G Rectifier.

LOUDSPEAKER:

Model 609-T:  
7 inch—Code No. AW19.  
Transformer—XA1.  
Field Coil Resistance—  
1100 ohms.  
V.C. Impedance—3 ohms  
at 400 C.P.S.

Models 707-C, 803-G:  
12 inch—Code No. AS17.  
Transformer—TX1.  
Field Coil Resistance—  
1500 ohms.  
V.C. Impedance—12.5 ohms  
at 400 C.P.S.

UNDISTORTED POWER OUTPUT ..... 4.2 watts

DIAL LAMPS (3) ..... 6.3 volt, 0.25 amp.

CONTROLS:

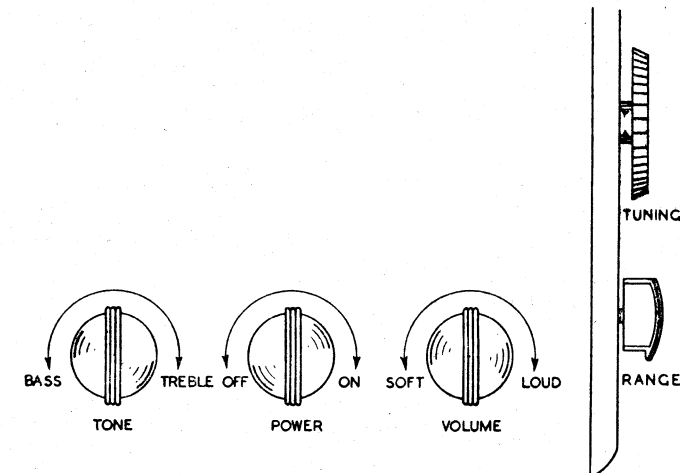

NOTE.—The three models covered in this booklet employ chassis of similar type, but which differ in the following details:—  
Table Model 609-T—Power transformer secondary volts suitable for 1100 ohms loudspeaker field.  
Console Model 707-C—Power transformer secondary volts suitable for 1500 ohms loudspeaker field.  
Combination Model 803-G—Identical with 707-C chassis with the addition of a 3 point socket for phono. motor mains connection.

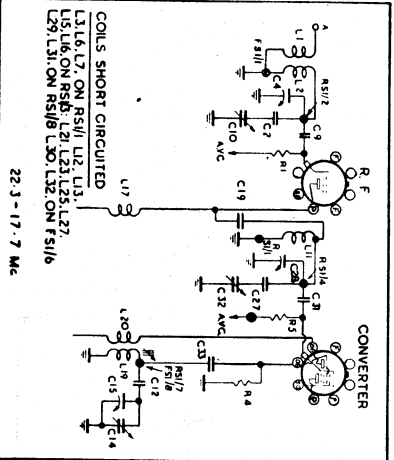
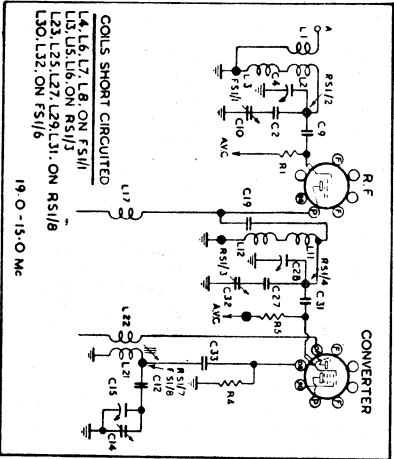
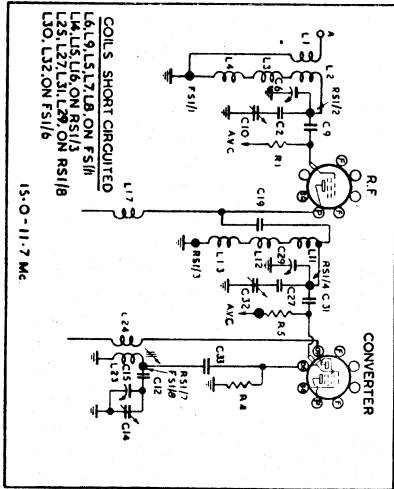
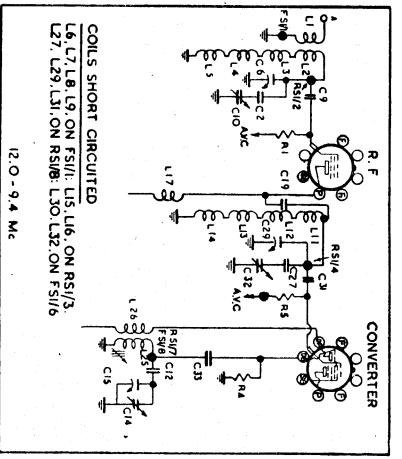
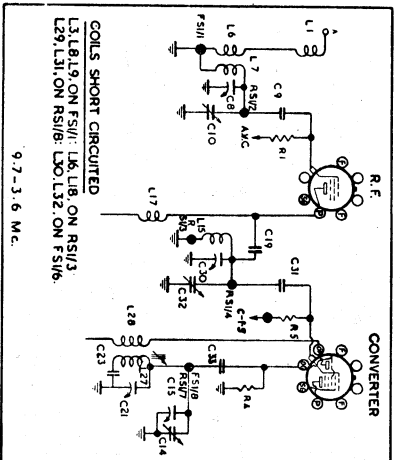
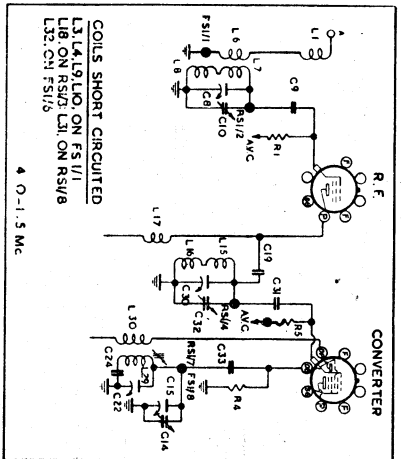
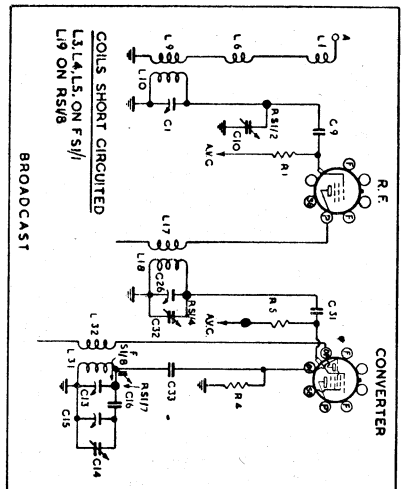

NOTE - ● INDICATES TWO OR MORE CONNECTIONS THROUGH SWITCH SECTION  
 ●●●●● REPRESENTS REAR OF SECTION 7  
 ●●●●● REPRESENTS FRONT OF SECTION 8

## PHONO. MOTOR AUTOMATIC STOP ADJUSTMENT.

The patent stop and switch is fully automatic.

As the needle travels towards the centre of the record, the pick-up arm moves friction plate A, which, through the friction pad and spring, carries with it the main lever B and trip lever C.

This main lever moves in towards the turntable spindle, on which is mounted the striker, which gently wipes against the rubber bush on end of trip lever C at each revolution, thus tapping back the main lever B (the friction between lever A and lever B allows this).

The "tapping back" process continues until the needle reaches the "run-in" groove in the centre of the record. The trip lever is now moved forward into the path of the striker, which strikes the side of the lever and trips the stop mechanism.

If stop fails to operate at finish of record, there is probably insufficient friction between lever A and lever B. This may be rectified by turning the friction screw in lever B in an anti-clockwise direction. If there is still insufficient friction, it may be that oil is present on the felt friction pad. If so, remove the pad and wash it in petrol to remove the oil.

When stop operates early, i.e., before needle reaches the end of the record, the trouble is either due to excessive friction or to the rubber bush on the trip lever being worn. Friction can be reduced by turning the friction screw clockwise.

As this adjustment is very sensitive, the screw should not be turned more than a quarter of a turn at a time. Excessive friction may cause a knocking sound to be heard in the loudspeaker and undue wear on the records.

When the rubber bush is worn, this may be turned round on its pin to expose a new face to the striker.

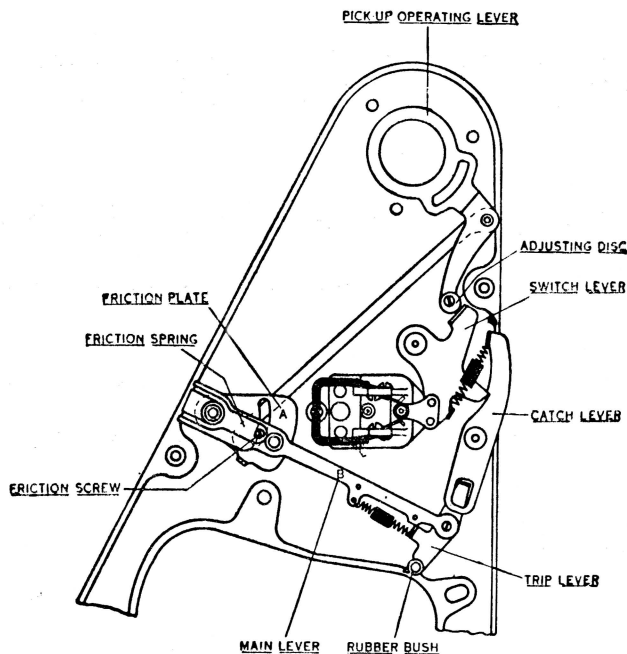

DIAGRAM OF AUTO-SWITCH FITTED TO TYPE E RADIOGRAM UNIT

## SOCKET VOLTAGES AND CURRENTS

Valve.	Control Grid to Chassis Volts.	Cathode to Chassis Volts.	Screen Grid to Chassis Volts.	Plate to Chassis Volts.	Plate Current mA.	Heater Volts.
6U7G R.F. Amp., M.W. ....	-3.9*	0	95	255	7.0	6.3
S.W. ....	-3.5*	0	95	255	7.0	—
6J89 Converter, M.W. ....	-3.9*	0	95	255	0.8	6.3
S.W. ....	-4.5*	0	95	255	0.6-0.8	—
Oscillator, M.W. ....	—	—	—	150	5.0	—
S.W. ....	—	—	—	150	5.0	—
6U7G I.F. Amp., M.W. ....	-3.9*	0	95	255	7.0	6.3
S.W. ....	-3.5*	0	95	255	7.0	—
6G8G/6B8G Detector ....	-1.5*	0	30*	125*	0.5	6.3
6V6GT/G Output ....	0	12.5	255	245	44.0	6.3
5Y3GT/G Rectifier ....	700/350 V.,	80 mA.	Total Current Drain			5.0

Measured with receiver connected to 240 volts A.C. supply.

Volume Control at maximum. No signal input.

\* Cannot be measured with ordinary voltmeter.

## MECHANICAL REPLACEMENT PARTS.

Item.	Part No.	Item.	Part No.
Cabinet, console .....	C69	Knob, range switch .....	5846
Cabinet, combination .....	C46	Knob, tuning .....	8075
Cabinet, table .....	C67	Mount plate assembly, tuning drive ..	17816
Cable, band indicator .....	19150	Pulley, brass .....	7885
Cable, loudspeaker .....	19087	Screen, I.F. transformer .....	3351
Cable, pick-up .....	19086	cap .....	8372
Cable, power .....	209	Screen, valve .....	8147
Cable, power switch .....	19089	cap .....	8148
Cable, volume control .....	19085	register .....	4733
Chassis end, right hand .....	10000	Socket, dial lamp .....	4194
left hand .....	9875	Socket, valve .....	4704
Clip, grid .....	7459	Socket, valve, cushion .....	7326
Cone assembly, loudspeaker—		Spindle, tuning drive, table .....	17739
Type AW19 .....	9356	console .....	9812
Type AS17 .....	9332	Spindle, range switch extension, table ..	19066
Core, magnetite, small .....	11403	console .....	19584
large .....	11400	Spindle, tuning control extension ....	19583
Dial frame assembly .....	19082	Spring, band indicator .....	8364
Dial scale .....	19100	Spring, drive tension .....	6641
Drum, band indicator .....	19094	Strip, tag, 1 way .....	7628
Drum, drive .....	9090	2 way .....	8863
Dust cover, loudspeaker—		3 way .....	9877
AW19 .....	9843	7 way .....	9879
AS17 .....	10306	Washer, felt .....	4935.
Knob .....	4589		

# MECHANICAL SPECIFICATIONS.

	Height.	Width.	Depth.	Overall Chassis Height .....	9
Cabinet Dimensions (inches)—				Weight (nett lbs.)—	
Table .....	12	26	11	Table .....	39
Console .....	32½	33	13	Console .....	84
Combination .....	32	36	16	Combination .....	150
Chassis Base Dimensions (inches)	3½	16	7½	Cabinet Finish .....	Walnut Veneer

## CIRCUIT ARRANGEMENT.

### 6U7G—V1.

The 6U7G is a triple grid, super control R.F. amplifier and is utilised for this purpose. The output of the aerial coil, which is tuned to signal frequency by the aerial section of tuning capacitor, is applied to the control grid for amplification. The cathode being earthed, a minimum negative bias voltage of 3.9 volts is obtained from the back bias circuit, and applied to the control grid via the A.V.C. line. Amplification is also controlled automatically, due to functioning of the A.V.C. circuit.

### 6J8G—V2.

The 6J8G is a triode-heptode converter and is employed as a frequency converter. Voltages at signal frequency are applied to the control grid from the R.F. amplifier via the R.F. coil and associate circuit. Local oscillations are provided by the triode portion of this valve operating as a tuned grid feedback circuit comprising oscillator coil, padding capacitor and oscillator section of ganged tuning capacitor. Electronic mixing gives a resultant heterodyne frequency of 455 kc/s. The cathode of this valve being earthed, bias voltages are applied to the control grid via the A.V.C. line from the back bias circuit. Minimum bias on medium wave is -3.9 volts and short wave -4.5 volts. The 6J8G is not A.V.C. controlled on short wave.

### 6U7G—V3.

The output from the 6J8G is coupled to the control grid of the 6U7G by the first I.F. transformer, which is permeability tuned to 455 kc/s. Bias conditions are similar to those of the 6U7G R.F. amplifier (V1).

### 6G8G/6B8G—V4.

The second I.F. transformer, permeability tuned to 455 kc/s, couples the output of V3 to the diode of V4 for detection. Portion of the R.F. voltage from this diode is fed to the A.V.C. diode by coupling capacitor (C44) and, in conjunction with diode load resistor (R10), develops a voltage which is applied to the A.V.C. controlled grids via the A.V.C. line. The A.V.C. voltage so developed varies in proportion to the strength of carrier being received. The audio component across the volume control is applied to the pentode section of V4 for amplification.

Valve types 6G8G/6B8G are interchangeable in this circuit.

### 6V6GT—V5.

The 6V6G is a tetrode power amplifier which is resistance-capacity coupled to V4, and is automatically biased. A negative feed-back tone control is employed. The output of the valve is coupled to the loudspeaker by the transformer T2.

### 5Y3GT—V6.

The 5Y3GT is a full wave high vacuum rectifier and supplies the D.C. requirements of the receiver.

## ALIGNMENT PROCEDURE.

Alignment should be necessary only when adjustments have been altered from the factory setting or when repairs have been made to the tuned circuits. Climatic conditions should not seriously affect the receiver.

It is important to apply a definite procedure, as given in this booklet, and to use adequate and reliable test equipment. Instruments ideally suited to the requirements are either the A.W.A. Junior Signal Generator type 2R3911, or the A.W.A. Modulated Oscillators type J6726 and C1070\*. An output meter is necessary with both these instruments, the recommended type having an output impedance of 5000 ohms and a range of 5-3000 milliwatts. The meter should be connected across the primary of the loudspeaker transformer with the voice coil of the loudspeaker open-circuit. If the output meter used is one which does not impress a load on the anode circuit of the output valve it will not be necessary to open-circuit the voice coil.

As the calibration of the band-spread bands requires great accuracy, it is recommended that an A.W.A. Crystal Calibrator, type 6795, be used after setting the oscillator calibration to check the accuracy of the signal generator. The crystal calibrator emits a modulated signal at intervals of either 100 or 1000 kc/s, throughout the radio frequency spectrum, thus providing a series of fixed and equally spaced calibration points of known accuracy. When using this instrument care should be taken to select the correct signal. With the crystal set at the 1000 kc. position, a spurious image signal can generally be obtained by turning the tuning control of the receiver to a point approximately 100 kc/s. higher in frequency. This is a useful check as to whether a harmonic or spurious image is being tuned. If a crystal calibrator is not available, broadcasting stations of known frequency may be used as an alternative.

When using a signal generator or modulated oscillator with the tuning of the receiver fixed, two frequencies can be tuned from the test instrument, one 0.92 Mc/s higher in frequency than the other. In all cases the desired frequency is the lower of the two.

A convenient alignment jig designed to hold the receiver chassis and fitted with a dial scale and pointer may be obtained from the Service Department of the company. With this jig alignment may be carried out with the chassis coupled to an actual scale, thus ensuring that the calibration will be correct when the chassis is placed in the cabinet; otherwise, use the 0-180° calibration scale on the drum. (See alignment table.)

For all alignment purposes connect the "low" side of the signal generator to the receiver chassis.

Perform alignment in the proper order as shown in the chart, starting from No. 1 and following all operations across, then No. 2, etc.

Keep the volume control set in the maximum clockwise position and regulate the output of the test instrument so that a minimum signal is introduced to the receiver to give a standard indication on the output meter. This will avoid A.V.C. action and overloading.

When the receiver has been satisfactorily aligned, seal the adjusting screws with a small quantity of cellulose cement.

\* If a type J6726 or C1070 instrument is used, see that a 250,000 ohm resistor is connected between the output terminals, and for short wave alignment a 400 ohm non-inductive resistor in series with the active output lead.

# CIRCUIT CODE

Circuit Code No.	Description	Stock Code or Part No.	Circuit Code No.	Description	Stock Code or Part No.	Circuit Code No.	Description	Stock Code or Part No.
<b>INDUCTORS.</b>								
L1, L2	Aerial Coil 22.3-17.7 Mc.	9852	R18	1 megohm, 1 watt 600, 541 or 600, 741		C39	70 uuF silvered mica	226, 460
L1, L2, L3	Aerial Coil 19.0-15.0 Mc.	9852	R19	50,000 ohms, ½ watt	600, 315	C40	110 uuF mica (Table only)	13211†
L1, L2, L3, L4—	Aerial Coil 15.0-11.7 Mc.	9852	R20	20,000 ohms, ½ watt	600, 307	C40	30 uuF mica (Console only)	13211†
L1, L2, L3, L4, L5—	Aerial Coil 12.0-9.4 Mc.	9852	R21	0.5 megohm, 1 watt 60, 535 or 600, 735		C41	0.0025 uF paper, 600v. working	228, 289
L6, L7	Aerial Coil 9.7-3.6 Mc.	9854	R22	50,000 ohms, ½ watt	600, 315	C42	110 uuF mica (Table only)	13211†
L6, L7, L8	Aerial Coil 4.0-1.5 Mc.	9854	R23	50,000 ohms, ½ watt (Console only)	600, 315	C42	30 uuF mica (Console only)	13211†
L9, L10	Aerial Coil Broadcast	9748	R24	250 ohms, 3 watt	602, 369	C43	0.02 uF paper, 600v. working (Table only)	228, 307
L11	R.F. Coil 22.3-17.7 Mc.	9853	R25	50,000 ohms, ½ watt	600, 315	C43	0.01 uF paper, 600v. working (Console only)	228, 301
L11, L12	R.F. Coil 19.0-15.0 Mc.	9853	R26	0.4 megohm, ½ watt	600, 333	C44	50 uuF mica	13211†
L11, L12, L13—	R.F. Coil 15.0-11.7 Mc.	9853	R27	0.1 megohm, ½ watt	600, 321	C45	0.1 uF paper, 400v. working	228, 121
L11, L12, L13, L14—	R.F. Coil 12.0-9.4 Mc.	9853	R28	0.1 megohm tone control	19007	C46	0.1 uF paper, 400v. working	228, 121
L15	R.F. Coil 9.7-3.6 Mc.	9855	R29	0.2 megohm, 1 watt 600, 527 or 600, 727		C47	0.1 uF paper, 400v. working	228, 121
L15, L16	R.F. Coil 4.0-1.5 Mc.	9855	R30	50,000 ohms, 1 watt 600, 515 or 600, 715		C48	16 uF, 525 P.V. electrolytic	
L17, L18	R.F. Coil Broadcast	9749	<b>CAPACITORS.</b>			C49	8 uF, 525 P.V. electrolytic	
L19, L20	Oscillator Coil 22.3-17.7 Mc.	9747	C1	52 uuF silvered mica ± 2 uuF		C50	0.5 uF paper, 400v. working	228, 135
L21, L22	Oscillator Coil 19.0-15.0 Mc.	9746	C2	12-430 uuF variable tuning (ganged)	18380	C51	0.005 uF paper, 600v. working	228, 295
L23, L24	Oscillator Coil 15.0-11.7 Mc.	9745	C3	200 uuF mica	13211†	C52	0.05 uF paper, 400v. working	228, 115
L25, L26	Oscillator Coil 12.0-9.4 Mc.	9744	C4	12 uuF mica	13211†	C53	1500 uuF mica	13213†
L27, L28	Oscillator Coil 9.7-3.6 Mc.	9743	C5	1-25 uuF air trimmer	19659	C54	200 uuF mica	13211†
L29, L30	Oscillator Coil 4.0-1.5 Mc.	9742	C6	1-25 uuF air trimmer	19659	C55	0.02 uF paper, 600v. working (Table only)	228, 307
L31, L32	Oscillator Coil Broadcast	9741	C7	12 uuF mica	13211†	C55	0.01 uF paper, 600v. working (Console only)	228, 301
L33, L34	1st I.F. transformer— 8286-Z, 8282*		C8	1-25 uuF air trimmer	19659	C56	25 uF, 40 P.V. electrolytic	
L35, L36	2nd I.F. transformer— 8287-Z, 8281*		C9	12 uuF mica	13211†	C57	0.016 uF paper, 600v. working (Table only)	228, 305
L37	Loudspeaker field— 1100 ohms (Table Model)		C10	1-25 uuF air trimmer	19659	C57	0.005 uF paper, 600v. working (Console only)	228, 295
L37	Loudspeaker field— 1500 ohms (Console Model)		C11	490 uuF mica ± 2½%	13212†	C58	0.5 uF paper, 400v. working	
<b>RESISTORS.</b>								
R1	1 megohm, ½ watt	600, 341	C12	2-10 uuF air trimmer	3658	<b>TRANSFORMERS.</b>		
R2	50,000 ohms, ½ watt	600, 315	C13	12-430 uuF variable tuning (ganged)	18380	T1	Power transformer 50-60 CPS	11344
R3	1 megohm, ½ watt	600, 341	C14	11-29 uuF air trimmer	3411 B		Power transformer 40 CPS	11346
R4	1 megohm, ½ watt	600, 341	C15	42 uuF Temp. Comp. N750		T2	Loudspeaker transformer (Table only)	XAI
R5	20,000 ohms, 1 watt 600, 507 or 600, 707		C16	2550 uuF mica ± 2½%	13213†		Loudspeaker transformer (Console only)	TXI
R6	0.1 megohm, ½ watt	600, 321	C17	1350 uuF mica ± 2½%	13213†	<b>SWITCHES.</b>		
R7	20,000 ohms, 1 watt 600, 507 or 600, 707		C18	2-20 uuF air trimmer	3611	S1	Phono-Range, 8 wafer, 8 position, rotary	19008
R8	16,000 ohms, 2 watt (2 x 32,000 ohms 1 watt in parallel) 600, 511 or 600, 711		C19	11-29 uuF air trimmer	3411 B		Note: Wafers numbered from front of chassis.	
R9	1.6 megohms, ½ watt	600, 345	C20	200 uuF mica	13211†	S2	Power switch, D.P.S.T. rotary	20007
R10	2.5 megohms, ½ watt	600, 349	C21	50 uuF mica	13211†			
R11	20 ohms, 3 watt, wire wound		C22	52 uuF silvered mica ± 2 uuF				
R12	20 ohms, 3 watt, wire wound		C23	12-430 uuF variable tuning (ganged)	18380			
R13	11 ohms, 3 watt, wire wound		C24	200 uuF mica	13211†			
R14	20 ohms, 3 watt, wire wound		C25	1-25 uuF air trimmer	19659			
R15	0.5 megohms, ½ watt	600, 335	C26	1-25 uuF air trimmer	19659			
R16	1.6 megohms, ½ watt	600, 345	C27	1-25 uuF air trimmer	19659			
R17	0.5 megohm volume control	19006	C28	1-25 uuF air trimmer	19659			
			C29	0.1 uF paper, 400v. working	228, 121			
			C30	0.05 uF paper, 400v. working	228, 115			
			C31	70 uuF silvered mica	226, 460			
			C32	70 uuF silvered mica	226, 460			
			C33	70 uuF silvered mica	226, 460			
			C34	4 uuF mica	224, 233			
			C35	0.01 uF paper, 600v. working	228, 301			
			C36	0.1 uF paper, 400v. working	228, 121			
			C37	0.05 uF paper, 400v. working	228, 115			
			C38	70 uuF silvered mica	226, 460			

\* Part number of winding only. Some receivers are fitted with I.F. transformers bearing part numbers 8286-Y and 8287-Y. These are wound with solid wire, consequently the D.C. resistance of the windings is higher than when litz wire is used. It should also be noted that when these transformers are fitted capacitor C34 is omitted.

† Capacitance and tolerance (if shown) to be quoted.



## SIMPLE SHORT WAVE CALIBRATION ADJUSTMENT.

The short wave calibration may be adjusted slightly, without removing the chassis from the cabinet for full alignment, by adjusting four cores, L19, L21, L23 and L25 after a station of known frequency is received.

The correct procedure is as follows:—

- (1) Set the dial pointer so that calibration is correct on the medium wave band.

- (2) To adjust the calibration of the 22.3-17.7 Mc. band, tune in the known station, and to shift the pointer position to the left, turn L19 clockwise or vice-versa until the station can be tuned in at its assigned frequency.

- (3) The adjustments for the 19.0-15.0, 15.0-11.7 and 12.0-9.4 Mc. bands are similar, using L21, L23, and L25 respectively.

## ALIGNMENT TABLE.

Alignment Order.	Test Ins. Connect to Receiver.	Frequency Setting.	Band Setting.	Calibration Scale Setting.	Circuit to Adjust.	Adjustment Symbol.	Adjust to Obtain.
1	6J8G Cap.*	455 kc.	Broadcast	0°	2nd I.F. Trans.	Core L36	Max. Peak
2	6J8G Cap.*	455 kc.	Broadcast	0°	2nd I.F. Trans.	Core L35	Max. Peak
3	6J8G Cap.*	455 kc.	Broadcast	0°	1st I.F. Trans.	Core L34	Max. Peak
4	6J8G Cap.*	455 kc.	Broadcast	0°	1st I.F. Trans.	Core L33	Max. Peak
Re-check 1, 2, 3, and 4.							
5	Aerial	600 kc.	Broadcast	19°	Oscillator†	Core L31	Calibration
6	Aerial	1500 kc.	Broadcast	168°	Oscillator	C14	Calibration
7	Aerial	1450 kc.	Broadcast	158°	Radio Frequency	C28	Max. Peak
8	Aerial	1450 kc.	Broadcast	158°	Aerial	C10	Max. Peak
Re-check 5, 6, 7, and 8							
9	Aerial	17.8 Mc.	22.3-17.7 Mc.	18°	Oscillator	Core L19	Calibration
10	Aerial	17.8 Mc.	22.3-17.7 Mc.	18°	Radio Frequency†	C26	Max. Peak
11	Aerial	17.8 Mc.	22.3-17.7 Mc.	18°	Aerial	C8	Max. Peak
12	Aerial	21.0 Mc.	22.3-17.7 Mc.	149°	Oscillator	C12	Calibration
13	Aerial	15.2 Mc.	19.0-15.0 Mc.	27°	Oscillator	Core L21	Calibration
14	Aerial	11.8 Mc.	15.0-11.7 Mc.	25°	Oscillator	Core L23	Calibration
15	Aerial	11.8 Mc.	15.0-11.7 Mc.	25°	Radio Frequency†	C25	Max. Peak
16	Aerial	11.8 Mc.	15.0-11.7 Mc.	25°	Aerial	C6	Max. Peak
17	Aerial	9.5 Mc.	12.0-9.4 Mc.	24°	Oscillator	Core L25	Calibration
18	Aerial	9.0 Mc.	9.7-3.6 Mc.	156°	Oscillator	C18	Calibration
19	Aerial	9.0 Mc.	9.7-3.6 Mc.	156°	Radio Frequency†	C27	Max. Peak
20	Aerial	9.0 Mc.	9.7-3.6 Mc.	156°	Aerial	C5	Max. Peak
21	Aerial	4.0 Mc.	9.7-3.6 Mc.	19°	Oscillator	Core L27	Calibration
Re-check 18, 19, 20 & 21							
22	Aerial	1.6 Mc.	4.0-1.5 Mc.	15°	Oscillator	Core L29	Calibration
23	Aerial	3.7 Mc.	4.0-1.5 Mc.	153°	Oscillator	C19	Max. Peak
Re-check 22 and 23							

Finally, re-check broadcast band. This is necessary only if the setting of C12 has been altered.

† Rock the tuning control back and forth through the signal.

\* With grid clip connected. A 0.001 uF capacitor should be connected in series with the "high" side of the test instrument.

The column headed "Calibration Scale Settings" refers to the 180° scale on the ganged tuning capacitor drive drum. In taking readings on this scale, read from the right-hand edge of the pointer, that is, the edge nearest the rear of the chassis. Check the setting of the drum before taking readings. The zero mark should be opposite the pointer with the tuning capacitor fully closed.

## CHASSIS REMOVAL AND REPLACEMENT.

- (1) Turn the Phono-Range Switch to the 22.3-17.7 Mc. position and then remove the three control knobs from the front of the cabinet. These knobs are each held by one set screw.

To remove the two knobs at the side of the cabinet, proceed as follows:—

**Table Model:**

The knobs pull straight off. Do not loosen the set screw in the lower knob. If difficulty is experienced in removing this knob, refer to the label adhered to the inside of the cabinet for instructions.

**Console Model:**

The knobs are not removed but the spindles to which they are attached are parted at the couplings within the cabinet.

- (2) Disconnect the dial pointer from the drive cord, first unscrewing the thumb nut, and disconnect the cable from the loudspeaker.

- (3) Disconnect the Bowden cable which actuates the band indicator on the dial scale. The cable is connected to the dial assembly at two points, the sheath to the top left-hand corner of the dial assembly (viewed from the rear) and the core to the band indicator. Loosen the thumb screws at these points and carefully free the cable from the assembly.

- (4) The chassis is held in the cabinet by four bolts. Remove these and withdraw the chassis from the cabinet.

- (5) Replacing the chassis in the cabinet is a direct reversal of the above instructions, but care must be taken to connect the dial pointer to the drive cord as follows:—

(a) Turn the tuning control to bring the ganged capacitor plates into full mesh.

(b) Connect the dial pointer to the drive cord with the pointer in a position opposite the setting mark on the dial scale, which is approximately 5/16 inch to the right of the 550 kc. calibration point

SEC  
PRI  
SEC  
PRI1  
1  
1  
1

BAND

7  
76  
5  
5  
5  
4  
3  
3  
3  
32  
2

## CONNECTION TO POWER SUPPLY.

The receiver should not be connected to any circuit supplying other than alternating current from 200 to 260 volts and at the frequency stated on the label within the cabinet. The power supply connection panel is shown in the accompanying diagram, and for 230 to 260 volt operation the input leads from the power switch (S2) should be connected to tags B and G. For operation on voltages below 230, connection should be made to tags B and W.

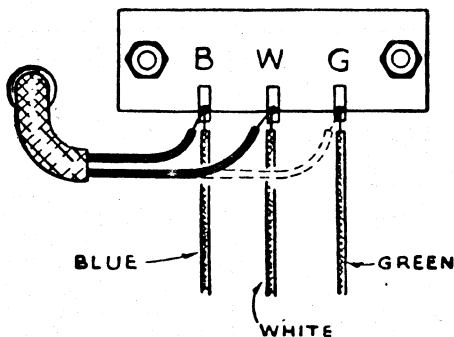

## "SERVICE WINDOW."

A "Service Window" is provided in the base of the table model cabinet. The "window" is normally covered with a perforated grille fastened by four knurled nuts. With the grille removed, it is possible to perform most service operations without removing the chassis from the cabinet.

## TUNING DRIVE CORD REPLACEMENT.

The accompanying diagram shows the route of the cord and the method of attachment. Whilst fitting the cord, keep it taut and adjust the length so that the tension

spring measures approximately 2 inches long when fitted. The spring should be sheathed to prevent it from rattling against the drum.

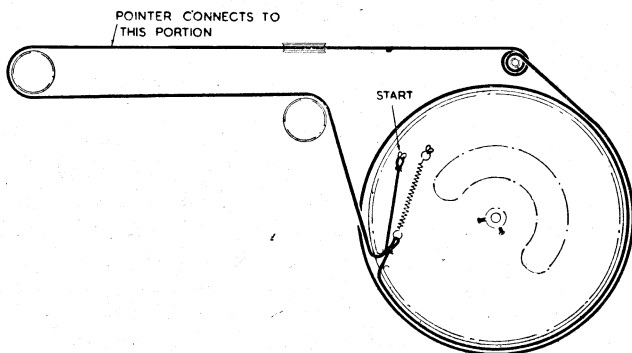

## LOUDSPEAKER SERVICE.

It is inadvisable to attempt loudspeaker repairs other than adjustment of the voice coil and replacement of the transformer. The fitting of a new cone or the replacement of a field winding should be done only by Service Departments suitably equipped to do the work.

To centre the voice coil, first remove the dust cover. To do this, use a sharp razor blade and cut the centre out of the dust cover, cutting just inside the edge of the voice coil former, which can be felt with the forefinger. Do not attempt to tear the cover from the cone. Loosen the suspension screws, insert three narrow paper "feelers" in the gap and re-tighten the suspension screws. The "feelers" should be approximately 3-16 inch wide and 0.006 inch thick.

After adjusting, test the loudspeaker, and, if satisfactory, fasten a replacement dust-cover in place with latex rubber cement. See "Mechanical Replacement Parts."

# DESCRIPTION OF TUNING CIRCUIT ADJUSTMENTS

## BROADCAST BAND.

The broadcast band adjustments follows usual practice with three trimming capacitors—C10 aerial, C28 R.F., C14 oscillator and a variable magnetite core for L.F. adjustment of the oscillator coil L31, L32.

## 9.7-3.6 Mc. BAND.

Adjustments are the same as those used on the broadcast band, that is, with three trimming capacitors—C5 aerial, C27 R.F., C18 oscillator and a variable magnetite core for L.F. adjustment of the oscillator coil L27, L28.

## 4.0-1.5 Mc. BAND.

All capacitors in the aerial and R.F. sections are common with those in the 9.7-3.6 Mc. band, the change of band being accomplished by switching tapped coils. The oscillator section, however, is provided with a separate capacitor, C19, for tracking with the signal circuits at the H.F. end and a variable magnetite core for L.F. adjustment of the oscillator coil L29, L30.

## 22.3-17.7 Mc. BAND.

At the L.F. end of this band there are three adjustments, a magnetite core in the oscillator coil L19, L20 and trimming capacitors C26 R.F. and C8 aerial. Small capacitors, C1, C22 and C15, are used in series with the ganged tuning capacitors to accomplish band-spreading at the L.F. end of this band. The oscillator circuit is made to track with the signal circuit at the H.F. end by adjustment of capacitor

C12. The three series capacitors are chosen to give three point tracking between the signal and oscillator circuits.

## 19.0-15.0 Mc. BAND.

The capacity system is the same as for the 22.3-17.7 Mc. band, the change of band being accomplished by switching coils, the oscillator coil L21, L22 being fitted with a variable magnetite core for L.F. adjustment.

## 15.0-11.7 Mc. BAND.

Adjustments are similar to those on the 22.3-17.7 Mc. band, excepting that no H.F. adjustment is provided for the oscillator. L.F. adjustments are trimming capacitors C25 R.F. and C6 aerial and a variable magnetite core in oscillator coil L23, L24.

## 12.0-9.4 Mc. BAND.

One adjustment only is provided, a variable magnetite core in the oscillator core L25, L26.

It will be noted that the ratio  $\frac{\text{max. frequency}}{\text{min. frequency}}$  is the same on the four bands, 12.0-9.4 Mc., 15.0-11.7 Mc., 19.0-15.0 Mc., 22.3-17.7 Mc., and the tracking is practically correct, using the same series capacitor for all bands. The ratio  $\frac{\text{max. frequency}}{\text{min. frequency}}$  is also the same on the 4.0-1.5 Mc. and 9.7-3.6 Mc. bands, but, due to the greatly different frequency spectrum of the oscillator, the series capacitors in the two oscillator circuits are different.



CIRCUIT DIAGRAM

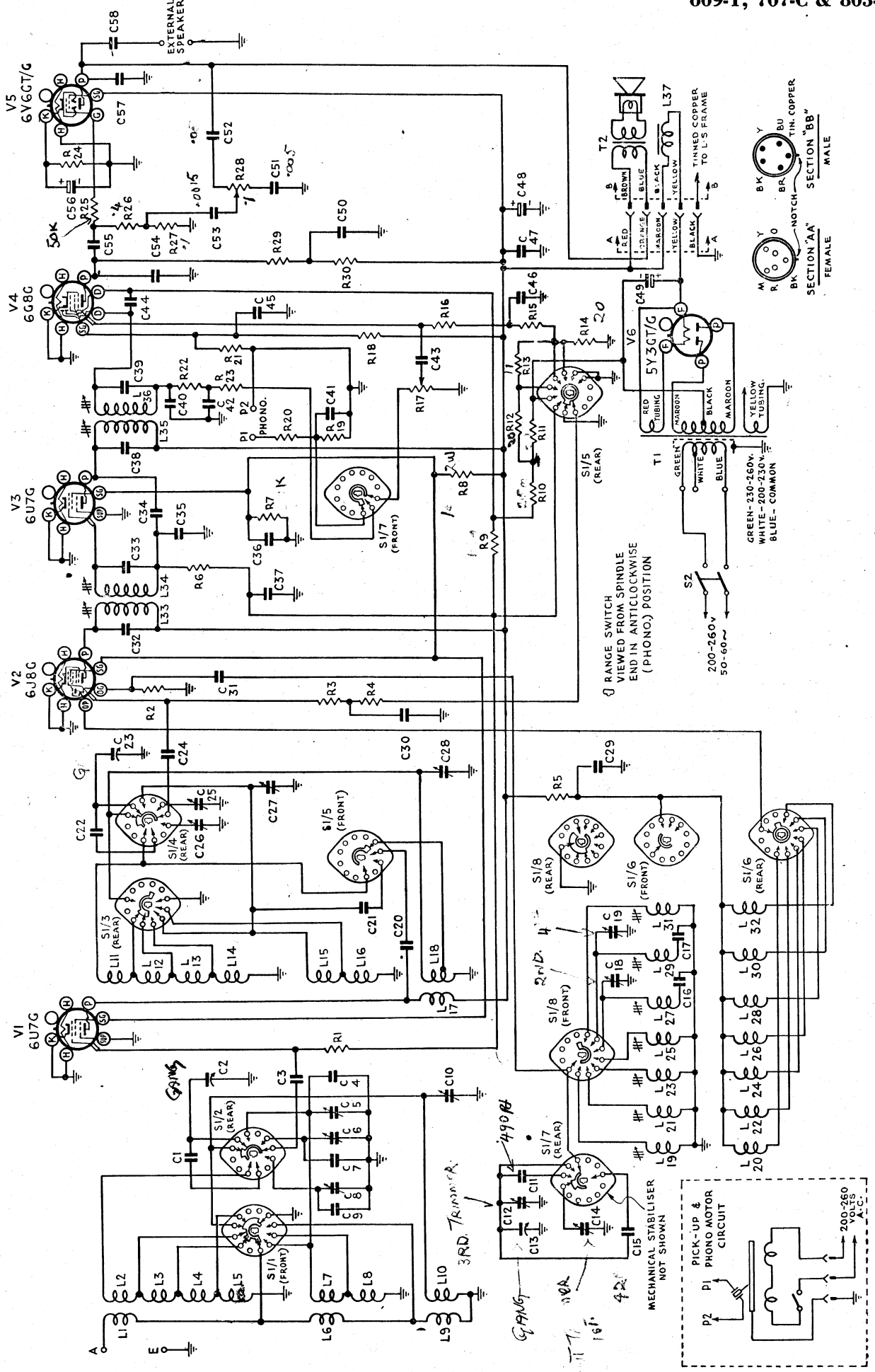

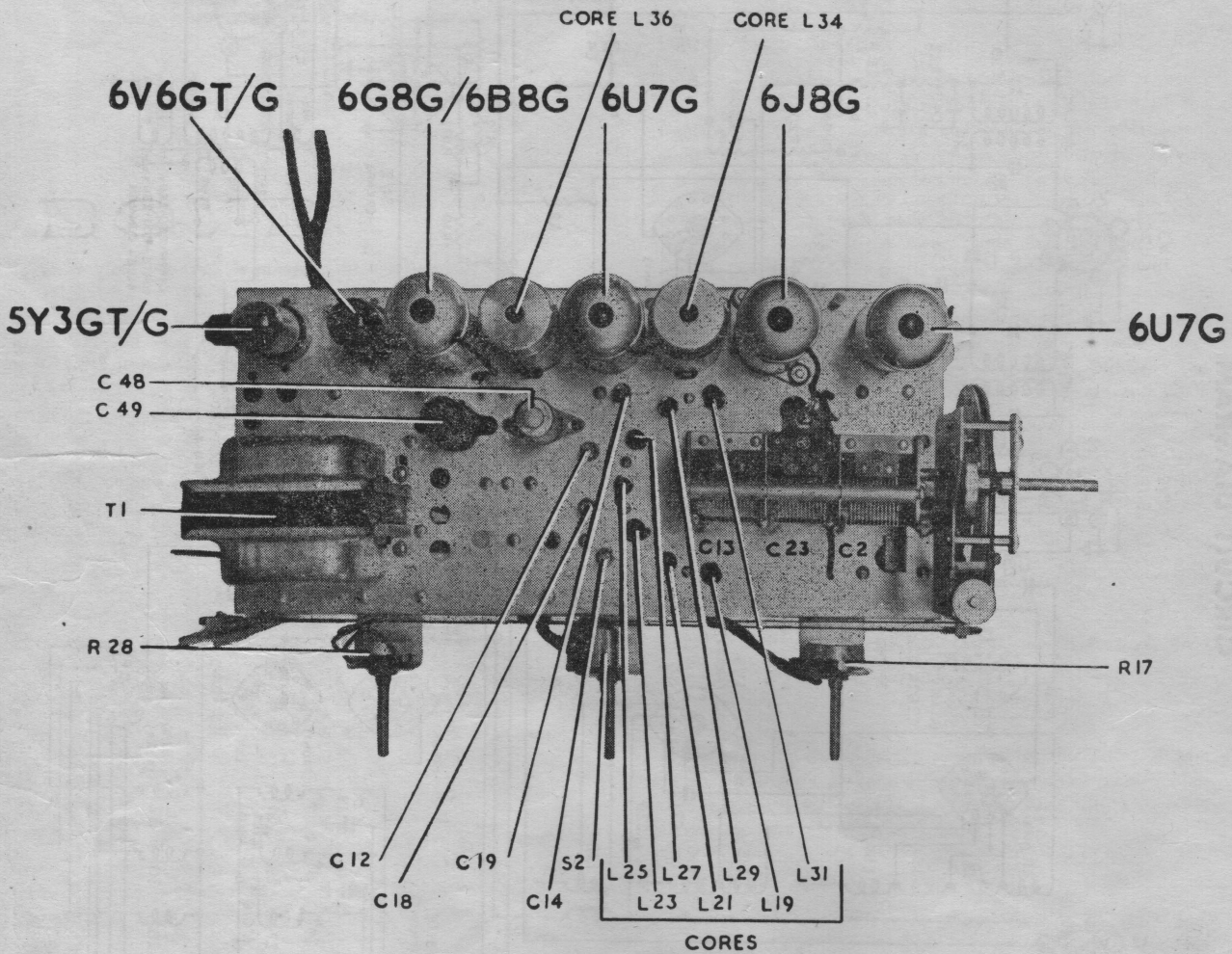

CHASSIS (Top View).

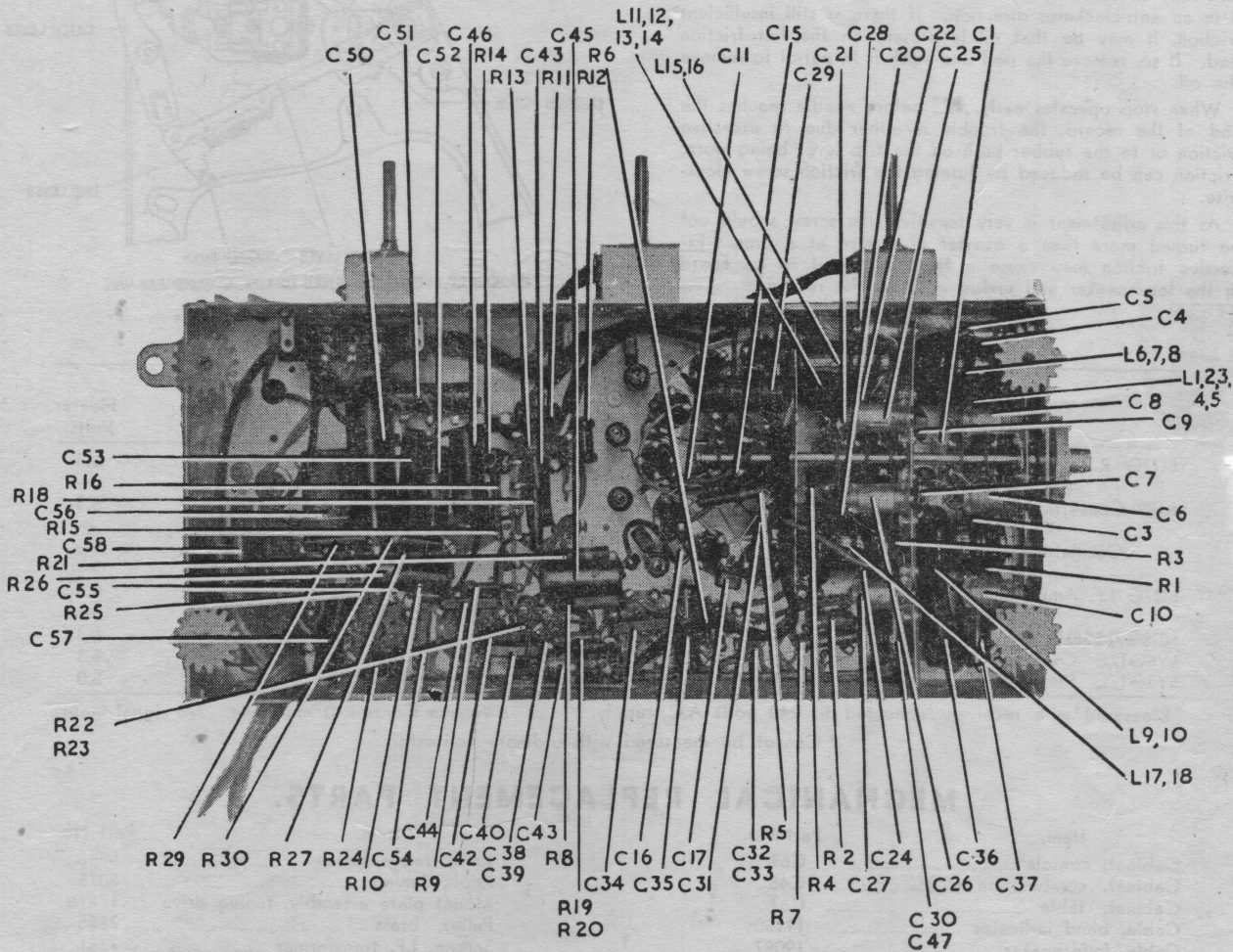

CHASSIS (Underneath View).

# CIRCUIT DIAGRAM

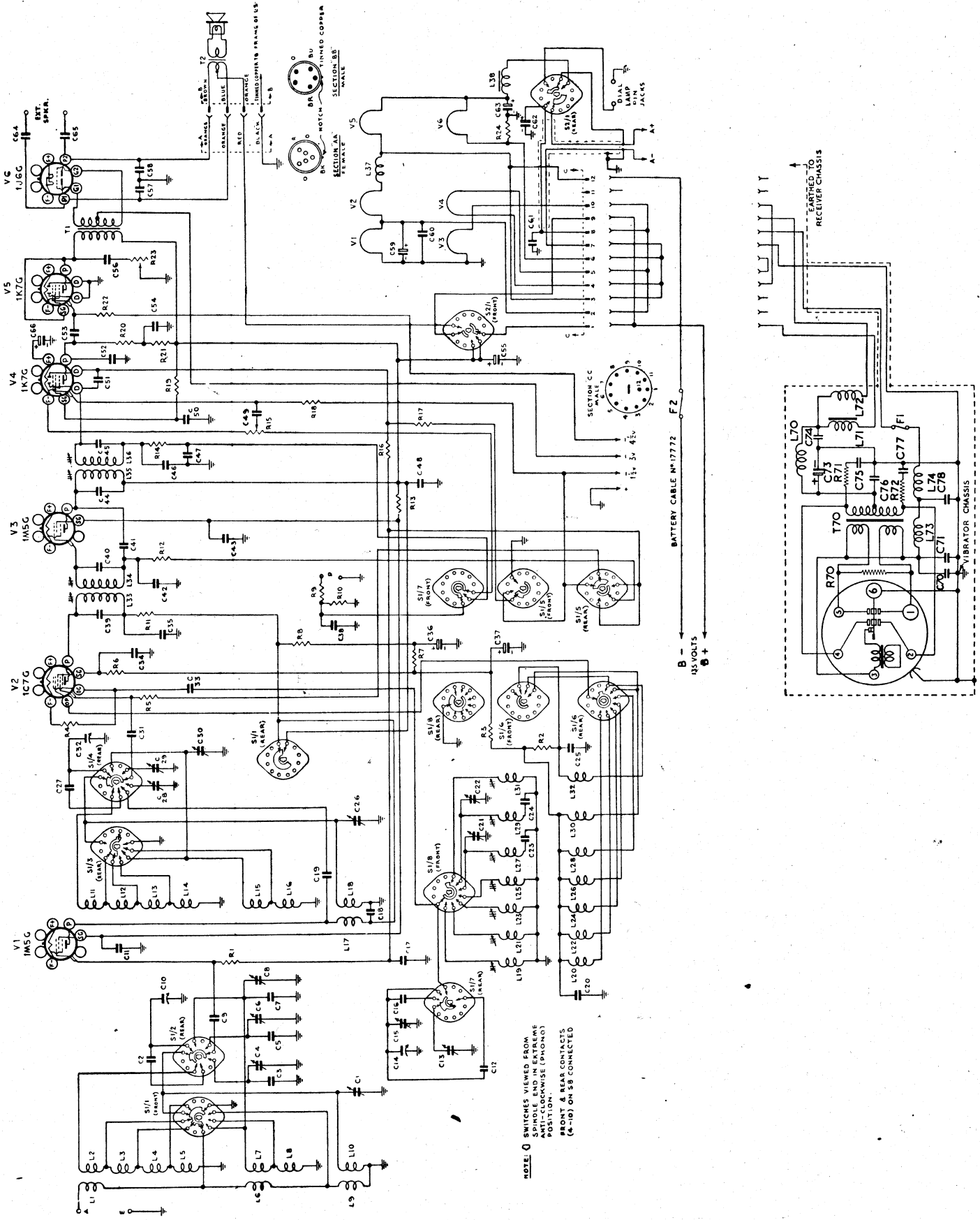

NOTE: 0 SWITCHES VIEWED FROM SPINDLE END IN EXTREME ANTI-CLOCKWISE (PHONO) POSITION.  
FRONT & REAR CONTACTS (4-10) ON SP CONNECTED

